

**INSTALLATION, USE AND MAINTENANCE HANDBOOK FOR MULTIPURPOSE, RE 90, REI 60, REI 120, DOUBLE LEAF REVERSIBLE AND NON-REVERSIBLE UNIVER DOORS**

Homologation no. BZ050REI060P028E1  
BZ050REI120P030F1

**NINZ** S.p.A.  
corso Trento, 2/A  
I-38061 ALA (TN) / ITALY

**I68-GB**  
5001505/2  
07/16 1/4

If not required specifically, the reversible UNIVER DOUBLE LEAF door will be standard delivered with opening "PULL RIGHT". To change the opening pull from RIGHT to LEFT, follow the instructions on page 3.

For door with ENVIRONMENTAL CHARACTERISTICS see also the enclosed complementary installation instructions.

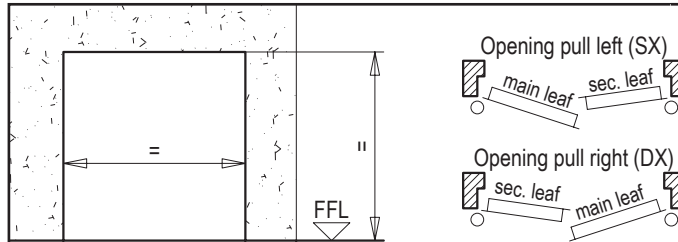

Unpack the materials, in case of fire-rated doors remove from the back of the doorframe the thermo expanding gasket FC that will be used for the operation in pos. 9. Verify the correspondence of the door's measures with the wall opening and the opening pull. The fire-rated reversible door will be even delivered from the factory with opening pull DX (right), to change the opening pull in SX (left) see the attached instruction.

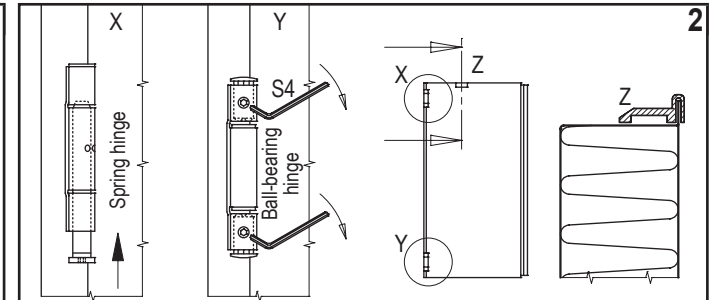

Fix the hinge frame on the secondary leaf putting in the pin for the spring hinge (X) and screwing on the blocking screw of the ball bearing hinge (Y). Perform the operation very carefully. Insert on the top and bottom the two spacers (Z) in equipment.

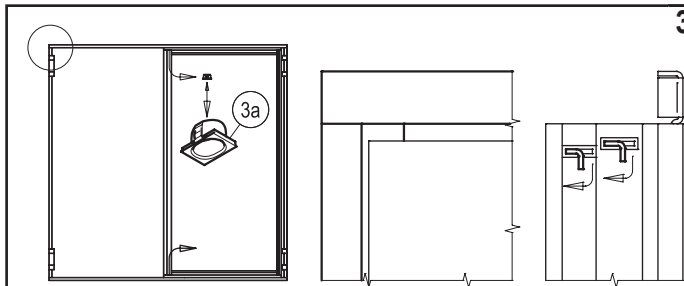

In case of multipurpose SECUR door, temporarily remove the two plastic inserts (3a) from transoms of doorframe. Join together the two transoms and the other hinge doorframe with the fixing flaps. Bend the flaps on the four corners to block the frame.

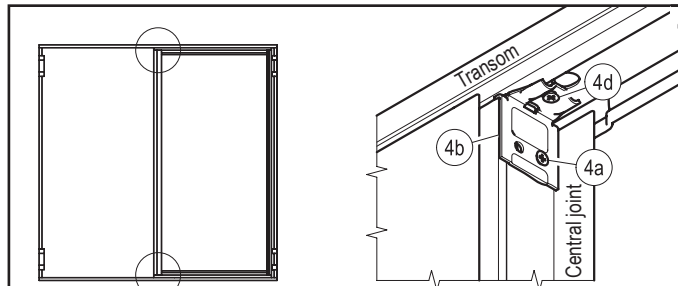

To make easier the following operation, release the prefixed screws (4a) of the angle bars (4b) placed at the top and bottom of the central joint. Fix the two transoms to the secondary leaf and screw them with the screws (4d) in equipment with the handle box. Fix very well all screws.

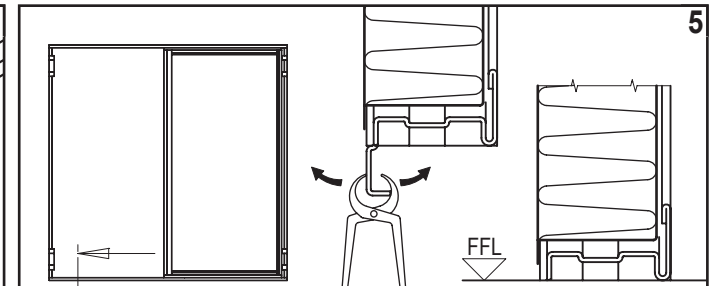

Once established the finished floor level (FFL) and decided that the door will be leaned without bottom frame, cut the jutting out fin of the lower transom so to lay the profile correctly on the finished floor level.

**APPLICATION WITH WALL ANCHOR 6a**

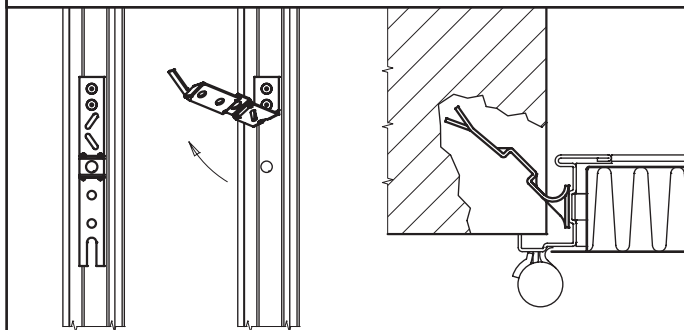

Bend up the wall anchors and mark on the wall their positions respecting the FFL level. Create the holes in the wall for the anchors.

**APPLICATION WITH STEEL GRUB SCREW 6b**

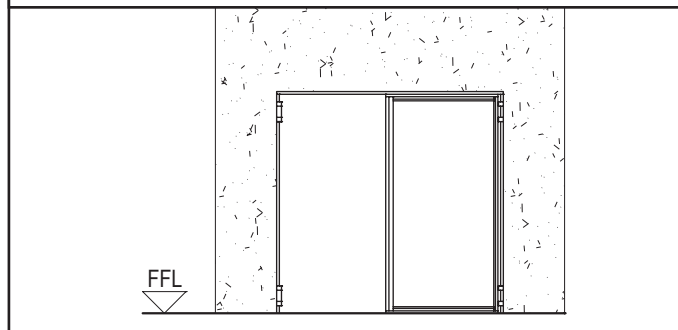

Fasten temporarily the door in the wall opening, respecting the plumb-line, the FFL level and the parallelism to the wall.

**APPLICATION WITH WALL ANCHOR 7a**

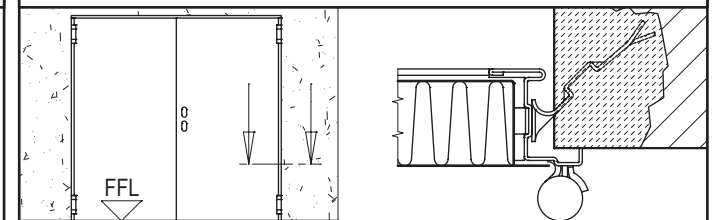

Install the principal door leaf and check that the two leaves are positioned at the same height (see point 2). Fasten temporarily the door in the wall opening, respecting the plumb-line, the FFL level and the parallelism to the wall. Fix the wall anchors with quick set cement. When the cement will be solid, remove the angle bars (part. 4b - draw. 4), to set free the inactive leaf. It is imperative to re-tighten both screws (4a) at top and bottom of inactive leaf.

**APPLICATION WITH STEEL GRUB SCREW 7b**

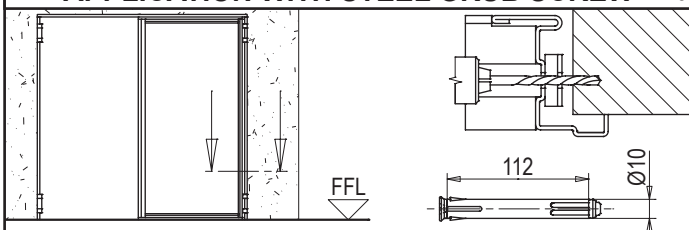

Fix the doorframe starting with the main leaf side using the prepared holes. In case of fire-rated doors use expansion screws Würth Art. No. 0910436112 (not supplied). Remove the angle bars, to set free the inactive leaf. It is imperative to re-tighten both screws (part. 4a - draw. 4) at top and bottom of inactive leaf. Fasten the remainder part of doorframe, operating as previously described. Install the main leaf operating as in point 2 described about the hinges.

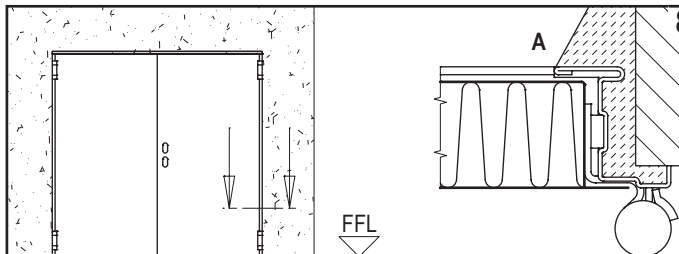

In case of fire-rated doors fill up the space between the doorframe and the wall with mortar (detail A) without curving the doorframe and covering it with plaster.

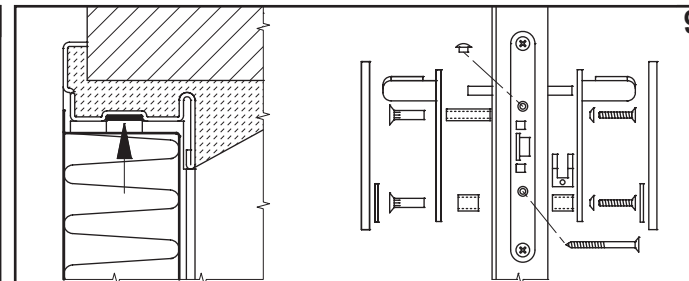

In case of fire-rated doors apply the thermo expanding gasket on the upper transom, but cut it before in two pieces with a measure that is going from the roller insert to the opposite angle of the doorframe. Mount the handle on the main leaf.

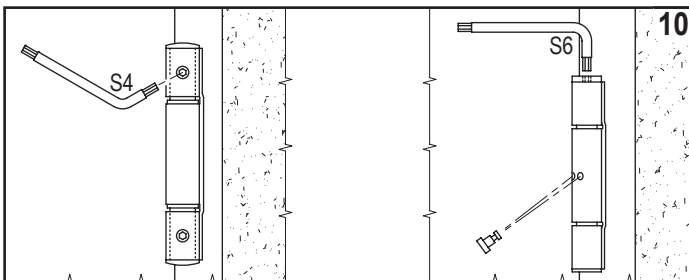

Remove all the plastic spacers between doorframe and leaf. Regulate the height of the leaves with the socket set screws of the ball bearing hinges. Wind up the springs in the opening direction and insert the tension pin. Even if self closing is not needed or overhead doorclosers are installed, blocking the hinge spring anyway with the tension pin.

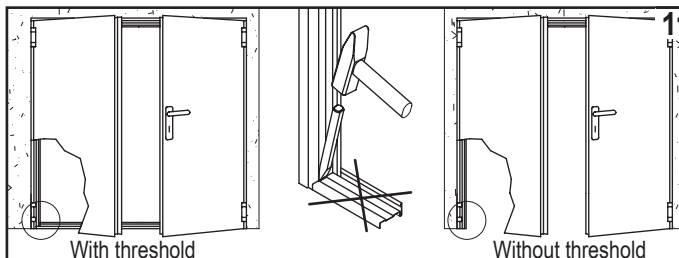

**Warning: the threshold does not be removed in case of door with environmental characteristics.**

In case the threshold is not required, remove it with a chisel. For multipurpose SECUR door: insert again the two plastic inserts (see dr. 3, part. 3a) onto transoms of the doorframe; if the threshold is not required: proceed to fix the SECUR floor catch.

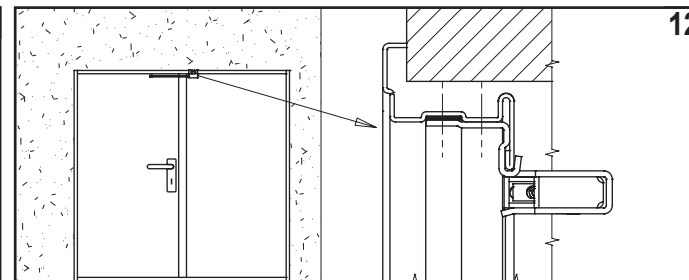

In case of fire-rated doors apply the bracket and the closing regulator following the handbook included in the RC/STD kit delivered with the door equipment.

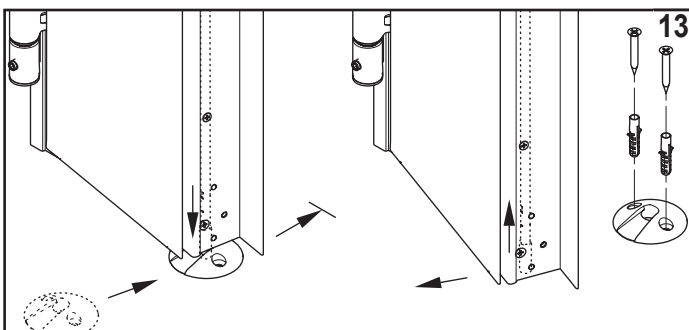

Install without lower rebate, position the floor catch beneath the passive leaf, close it and insert the lower rod into the floor catch. Open the leaf without moving the floor catch and fix it to the floor with screws and plugs.

**SECONDARY LEAF of MULTIPURPOSE DOOR**

In case of application of panic bar onto not predisposed secondary leaf, remove the manual lever lock and drill the leaf sheet on the push side. Then install the AP 020P antipanic lock for fire-rated door or AP 020U for multipurpose door. Proceed with installation of the panic bar by following the specific handbook.

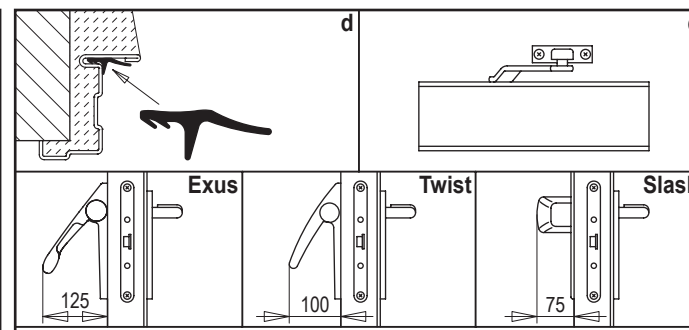
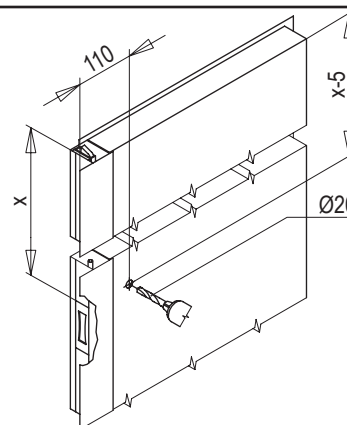

Accessories: d) rebate sealing; e) overhead doorcloser (the spring hinge must be anyhow slightly loaded); EXUS, TWIST or SLASH panic bar.

# INSTALLATION INSTRUCTION TO CHANGE THE OPENING PULL OF A UNIVER DOUBLE LEAF DOOR FROM DX (RIGHT) TO SX (LEFT)

**NINZ** S.p.A.  
 corso Trento, 2/A  
 I-38061 ALA (TN) / ITALY

**I68-GB**

3/4

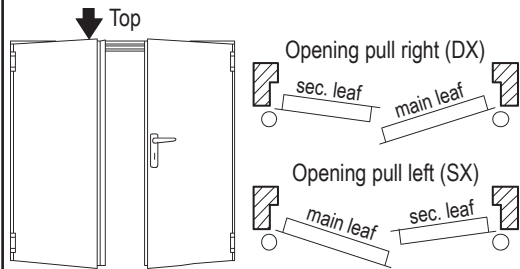

As standard the fire-rated door will be delivered from the factory with opening pull DX (right). To change the opening pull in SX (left) follow the next easy instructions.

**1**

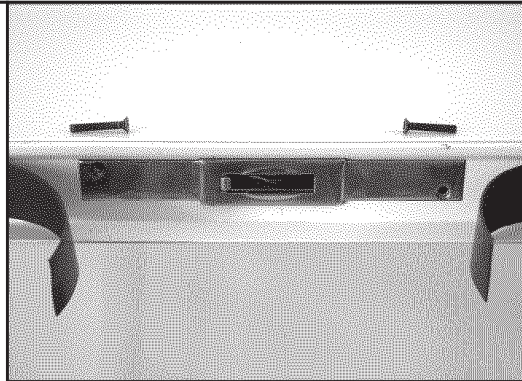

**2** Remove part of the thermo expanding gasket FC, unscrew the two screws and remove the central lock.

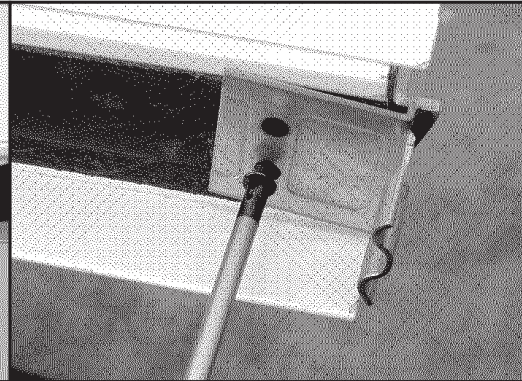

**3** Remove the upper and lower external plates.

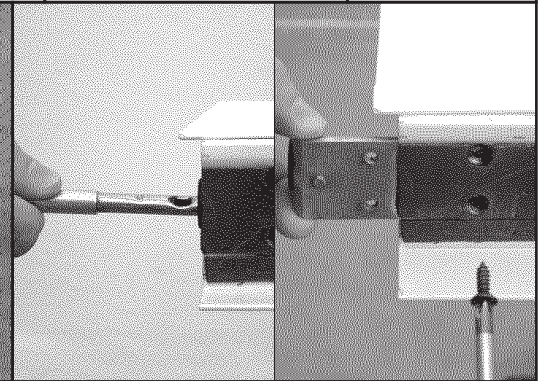

**4** Remove the lower rod and the respective angle bar.

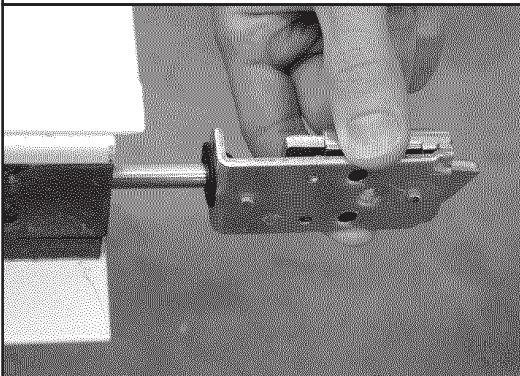

**5** Remove the upper rod, the upper device and the respective angle bar.

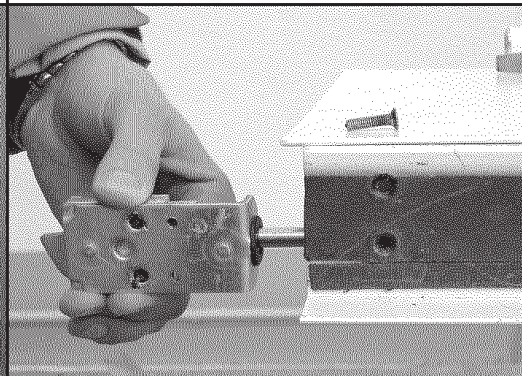

**6** Turn the upper device on its support and insert the rod on the opposite side of the leaf respect the starting position.

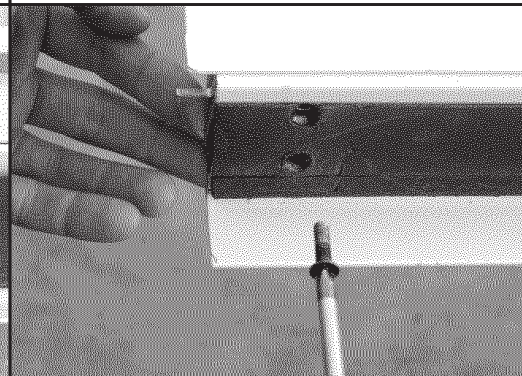

**7** Screw the upper device with its own angle bar with the screw M5.

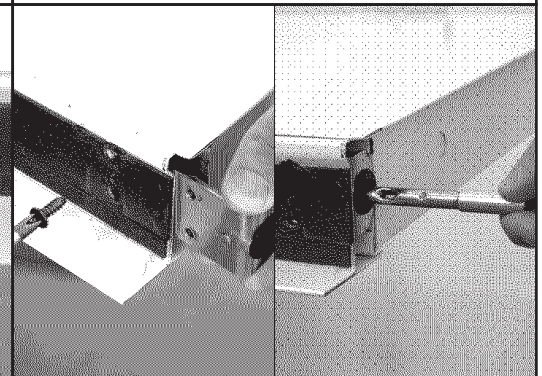

**8** Screw the internal, lower guiding angle by the self-tapping screw and insert the rod.

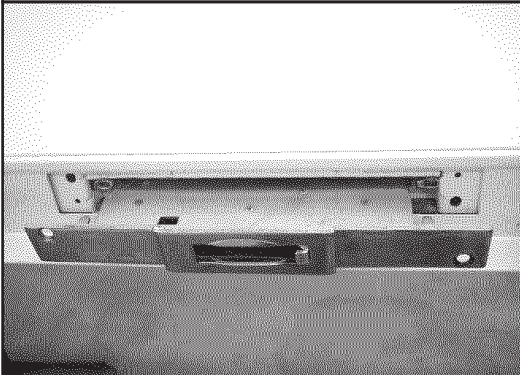

**9** Insert the central lock with the hook drive turned look down. Make sure that the two rods will be coupled.

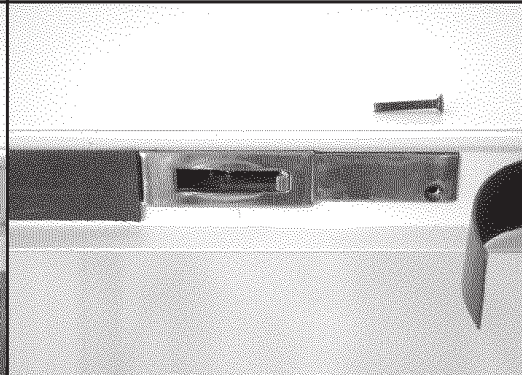

**10** Screw the lock (M6 screw) and stick again the thermo expanding gasket FC, add if necessary two drops of silicone.

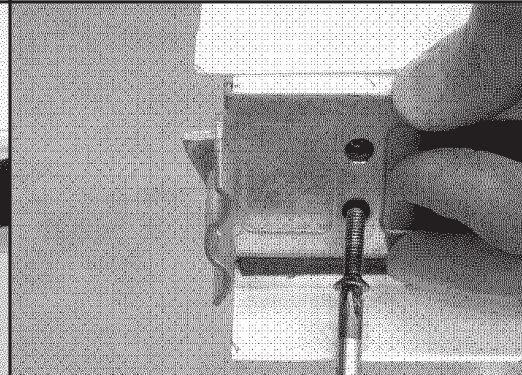

**11** Screw again the upper and lower external plates (M5 screw on device side).



**Instruction  
of the door**

**12** Go ahead following the general installation instruction of the door.

**GENERAL NOTES**

**STANDARD:** the assemble instructions have to be followed in every detail to respect the test conditions and assure the perfect functioning of the door, including the self-closing of fire-rated doors. Furthermore a regular service is necessary. Multipurpose doors are not endowed with thermoexpanding gaskets and closing regulators.

**LIABILITY:** it is duty of the installer to follow the installation instructions in any detail, specifically point 2, 7a, 7b and 10 reported at pages 1 and 2, in order to guarantee the safety of the end-users.

**MASONRY WORKS:** it is the customer's responsibility to keep the wall integral particularly in the anchor points of the door, to fill the space between doorframe and wall with mortar as indicated in box 8 on page 2 (detail A) of the present instructions and to execute the masonry works in accordance to standard UNI 9723.1990/A1. All this is particularly valid for fire-rated doors.

**FINISHING:** the serial door is finished with an epoxy-polyester powder paint oven-baked at 180 °C. The surface is orange-skin and particularly resistant. In case an additional paint is desired we advise to follow these instructions:  
- make smooth the surfaces with sandpaper and dust them;  
- apply a base coat of semi-gloss acrylic (suggested product: ACRILFIN SL series 567 + 20% by weight aliphatic hardener series E872003 - made by ELCROM, Italy);  
- finish the surfaces with enamels or paints to your choice.

**CLEANING:** the doors are supplied from the factory clean and packed. We suggest to use a clothe and soaped water only. Do not scratch the surfaces.

**WARRANTY:** the manufacturer gives warranty as per Italian law (C.C.1495). Any claim for missing or damaged goods have to be recorded by inserting a written remark in the delivery notes and must be notified the maximum within eight days from the date of materials receipt.

**CURRENT CE MARKED ACCESSORIES FOR FIRE-RATED DOORS:**

Std015 lock:	CE 0497/CPD/4265/11	- EN 12209:2003/AC	- 3 M 3 1 0 C 2 H A 2 0
Hinges:	CE 0789-CPD-2005	- EN 1935:2004	- 4 7 7 1 1 4 0 14
RC/STD closing regulator:	CE CPD-0425-1153	- EN 1158:2003	- 3 5 5/3 1 1 4

The CE marking of the Std 019 lock for inactive leaf of two-leaved fire-rated doors is only valid if a panic bar or emergency handle is installed onto main leaf.

**USE AND MAINTENANCE INSTRUCTIONS FOR UNIVER DOORS**

All fire-rated doors located in escape routes need regular maintenance in order to verify that no damage occurred and that they close regularly. The scheduled maintenance shall guarantee that the leaf swings correctly and that the self closing mechanism works properly. The doors shall be kept free from any obstructions. Doors must be kept free from obstructions.

Any 5.000 opening cycles but at least every 6 months the following operations shall be carried out:

- lubricating the ball-bearing hinges;
- lubricating the spring hinges and the springs after removing the tension pins.
- wind up the springs inserting the tension pins. Verify that the closing force is sufficient to shut the door if opened to 30±2°;
- lubricating the lock and the latch.
- verify the functionality of the secondary leaf's rods and lubricate its guide rail;
- clean the hole of the floor catch set;
- lubricate the lock and the self-locking device (top);
- verify the regular functionality of the closing regulator (arm position perpendicular to the main leaf). Lubricate the mobile parts of the closing regulator.

Verify the regular functionality of the doors accessories (handle, panic bar, overhead doorcloser etc.). Their mobile parts shall be lubricated too.

In case of irregular functioning of the door or its accessories contact an authorized installer or replace the damaged accessories.

N.B.: For lubrication use viscous products.

**HANDLING AND STORAGE - COMPLAINTS**

**HANDLING:** in case of handling with webbing slings/ropes, place them under the feet of the pallet; avoid to place them under the boards; avoid that the action of slings/ropes produces too much pressure upon the doors, by means of spacers interposed in the upper part. Do not handle the leaves using suction caps. **STORAGE:** it is duty of the company/person taking over the doors to store them in a suitable place so that they will be protected from the natural agents and from the direct sun rays. If during transportation or truck unloading it rains or snows on the doors it is necessary to remove immediately the nylon film from each leaf and doorframe put them in vertical position to dry appropriately. **COMPLAINTS:** in case of external visible defects on doors, they have to be marked in the copy of the transportation document to be returned to the forwarder and notified to the manufacturer by registered mail within 48 hours. We remember that according to our general conditions intrinsic defects have to be notified to the manufacturer within 8 days from the delivery date by registered mail. Goods with defects never have be utilized or assembled, they should be stored at disposal for controls by the manufacturer appointed person.

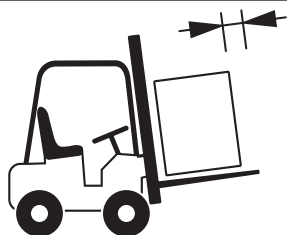

Move the materials with appropriate means.

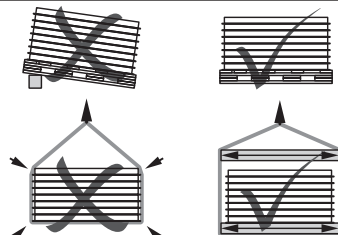

Store and handle the materials with care.



Assemble by qualified staff only.



Do not expose the materials to the natural agents.